

Customer Name

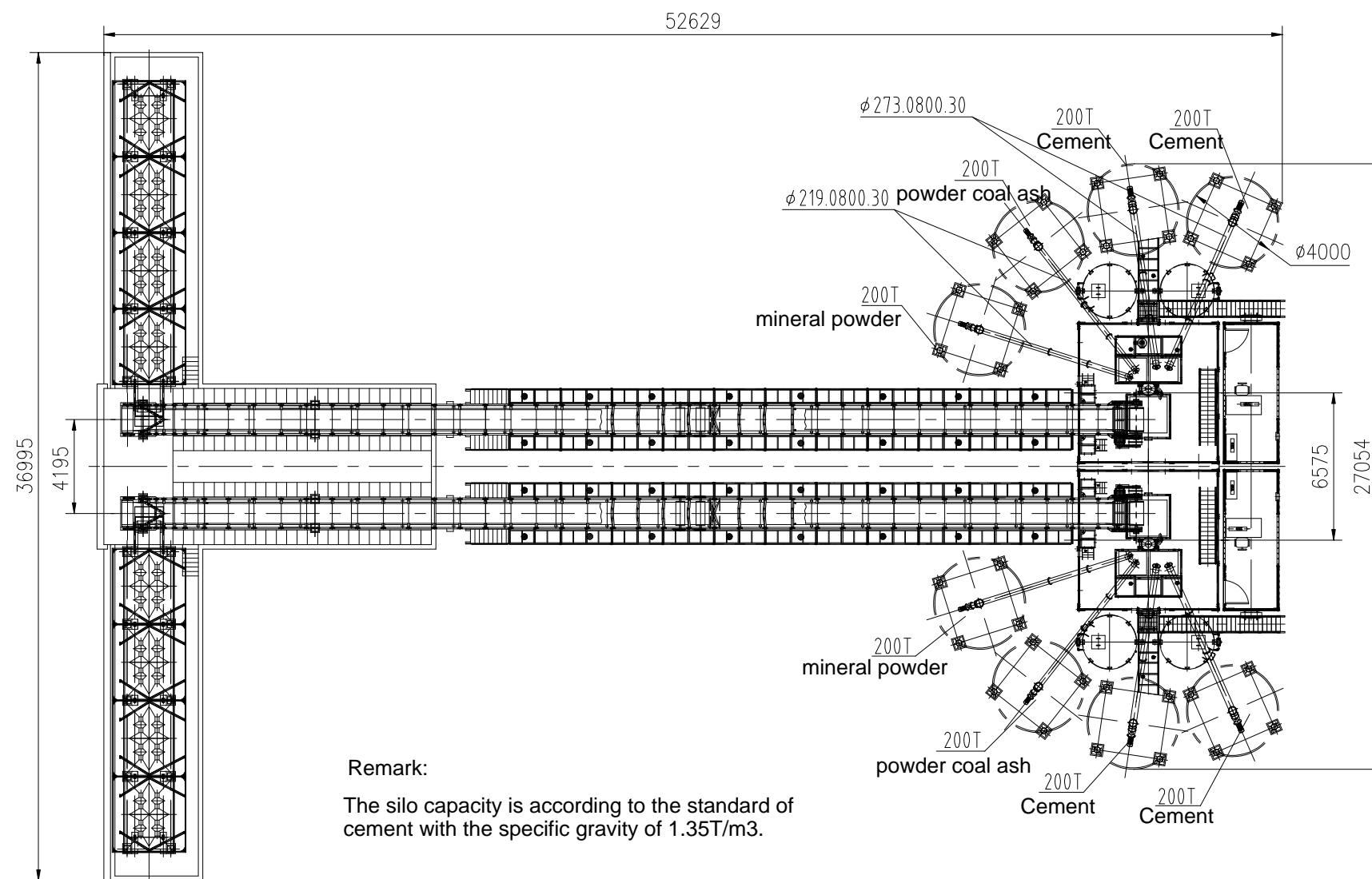
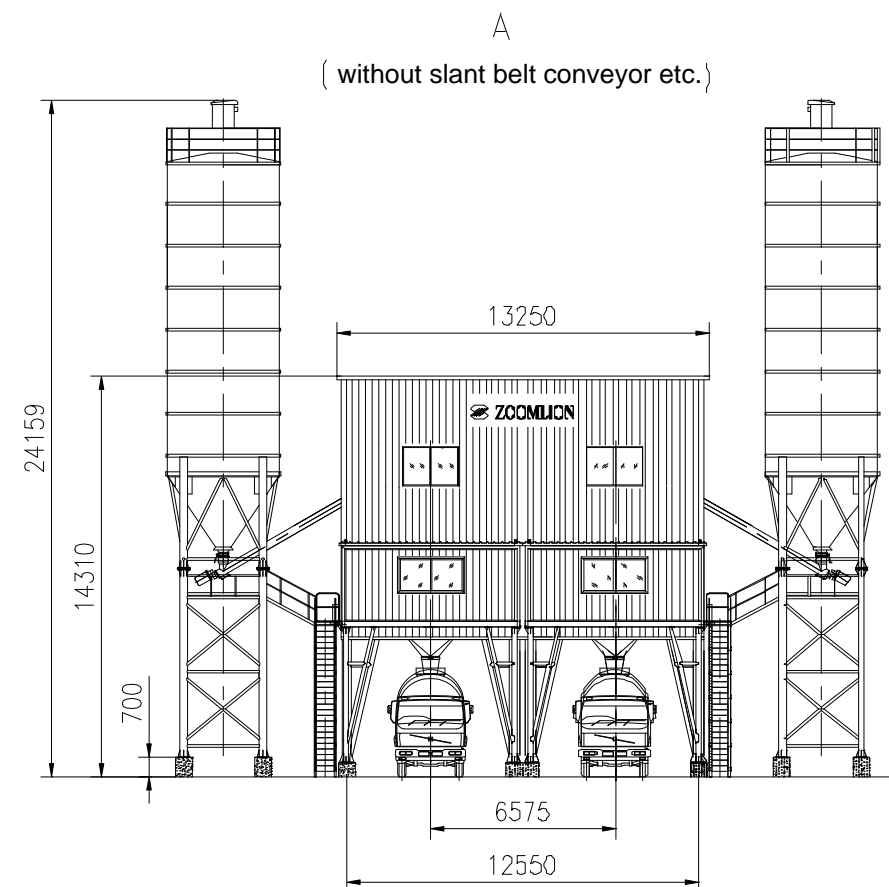
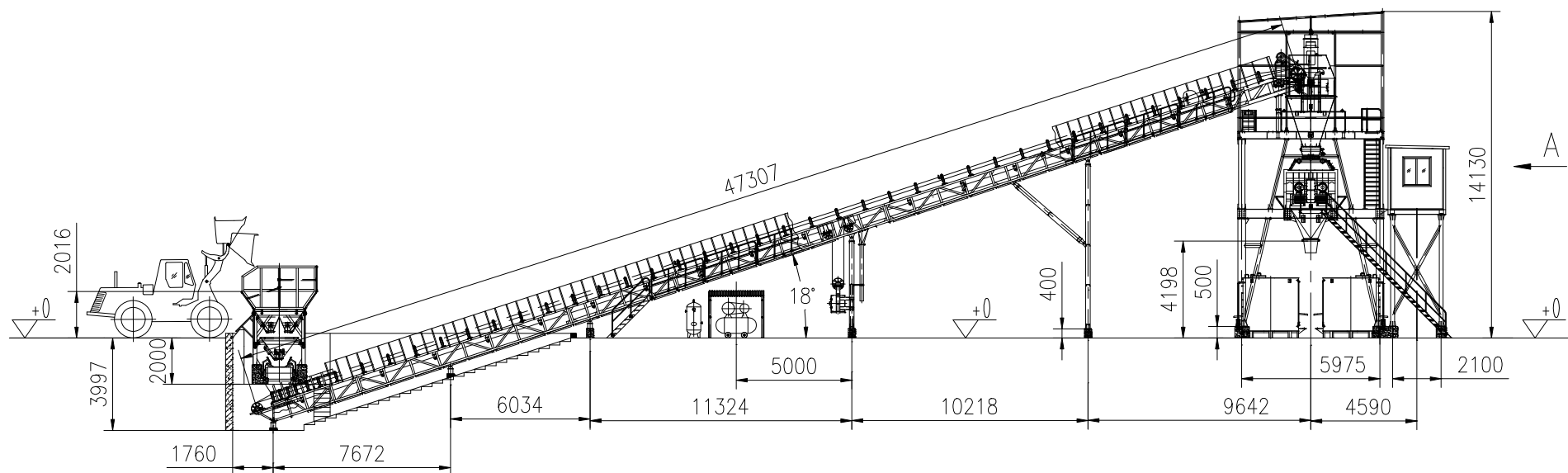

Remark:
The silo capacity is according to the standard of cement with the specific gravity of 1.35T/m³.

Major Technical Data

Max. Thero Production Capacity (m ³ /h)	2×120
Discharge Height (m)	4
Main Mixer Model	MAD3000/2000SDSHO
Production Time (s)	60
Capacity of Aggregate Hopper (m ³)	2×4×25
Capacity of Belt Conveyor (t/h)	900
Capacity of Spiral Conveyor (t/h)	90
Total Power (kW)	2×210
Batching Range and Accuracy of Aggregates (kg)	(0-3000)±2%
Batching Range and Accuracy of Cement (kg)	(0-1000)±1%
Batching Range and Accuracy of Flyash (kg)	(0-500)±1%
Batching Range and Accuracy of Water (kg)	(0-500)±1%
Batching Range and Accuracy of Additive (kg)	(0-30)±1%

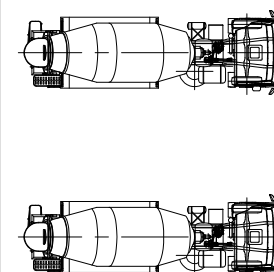

ZOOMLION
2×HZS120 Concrete Mixing Plant
Equipment Layout Drawing
Customer Name